



KEEP REENGINEERING, KEEP INNOVATING

FEED MANAGEMENT SYSTEM

FEED WEIGHER



Features

- Regulating feed distribution and poultry production by installing the Weigher between the silo and the feeder.
- Supervising feed mixing in animal production mills.
- Controlling color and material blending in the plastic industry.
- Bagging under the weigher for feed, fertilizer, and wood.
- Blending different granules in industrial facilities.



Removal panel for easy access to mechanical weigher.



Back panel easily remove for maintenance.



Viewing window in access panel provides view of the sensor and internal system.



Handle to lift the casing for maintenance.



Distribution auger connection- Lower bottom boot connection can be rotate according to need.

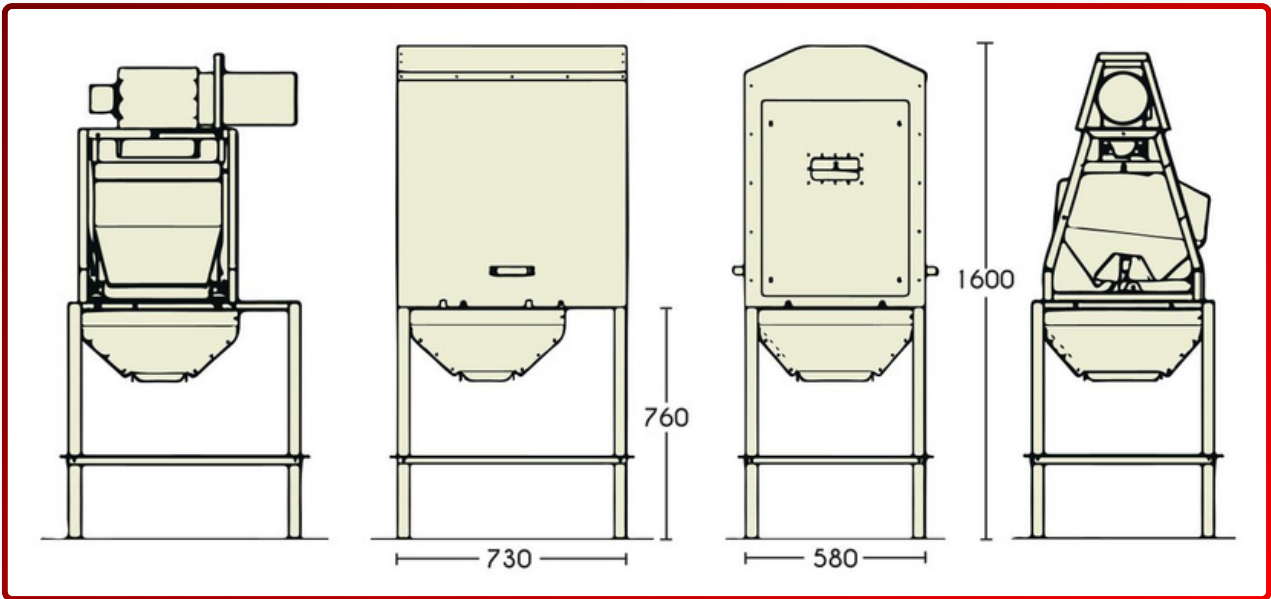

The mechanical weigher give us an accurate and reliable method of weighing a continuous feed flow passing through the weigh chamber to measure up to 100 tips per hour with range of 6 to 12kg per batch.

Technical Specification



Weigher Type	:	8
Content, kg/compartiment (normal)	:	10
Content, kg/compartiment (min/max)	:	6-12
Scale volume, per compartiment	:	26
Net weight, kg	:	30

Monitor feed amount fed to a single pen to improve feed management and optimise profits.

Pristine Glory Sdn. Bhd.
Poultry Equipment Manufacturer
 (Co. No.: 353246-W)

Pristine Dynamics Sdn. Bhd.
Poultry Project Developer
 (Co. No.: 352630-T)

+605 366 6988 |
 +605 366 6998
 +605 363 3299
 pristine@pristine.com.my



PT8638, Jalan Johan 2/6, Kawasan Perindustrian
 Pengkalan, Fasa 2, 31550 Pusing, Perak Darul
 Ridzuan, Malaysia